

Tlumiče nárazu ▪ Shock Absorber

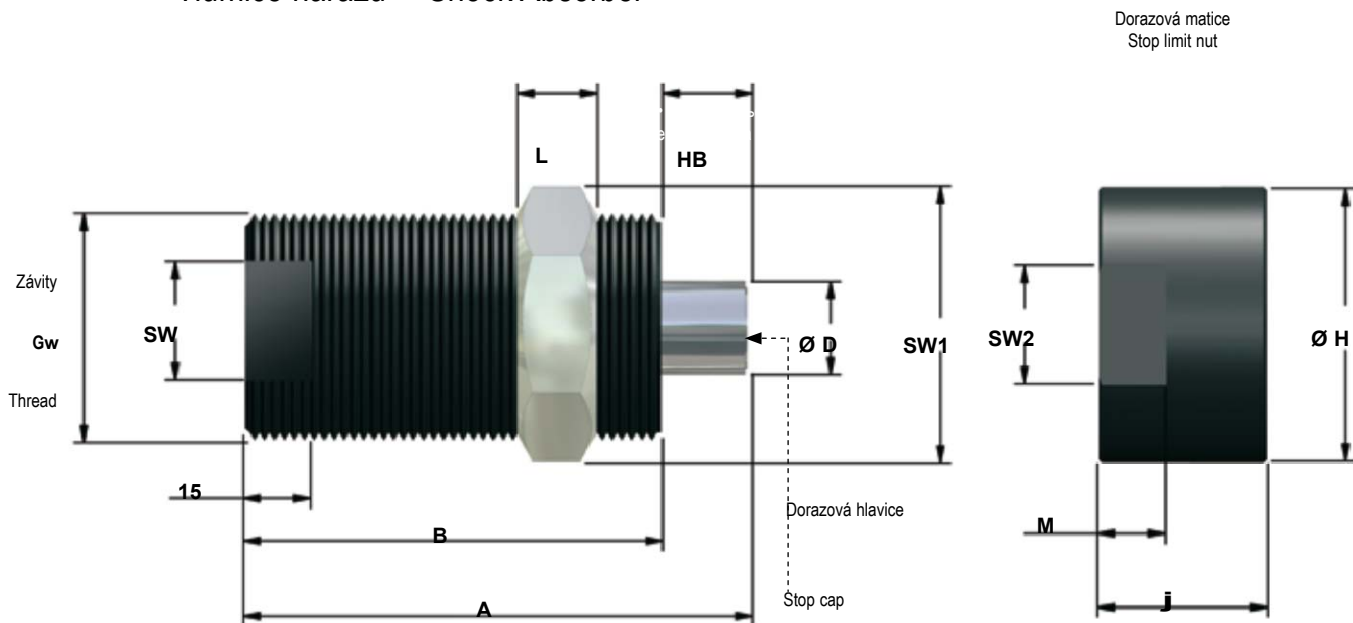

ROZMĚRY ▪ DIMENSIONS

	GW	A	B	Ø D	Ø H	J	L	SW	SW1	SW2	M
		mm	mm	mm	mm	mm	mm	mm	mm	mm	mm
USSK-M 0,5	M 20 x 1,5	49	42	6	25	16	6	18	24	22	8
USSK-M 1,0	M 25 x 1,5	58	50	8	34	18	8	23	30	30	10
USSK-M 1,1	M 30 x 1,5	67	55	10	40	20	8	28	36	36	10
USSK-M 1,25	M 32 x 1,5	67	55	10	40	25	8	30	41	36	10

TECHNICKÉ PARAMETRY ▪ PERFORMANCE

	Zdvih Stroke	Přijem energie Energy absorption		Efektivní hmotnost - Effective mass			Nárazová rychlost Impact Speed	Síla vratné pružiny Return spring force		Hmotnost Weight
				-1 (soft)	-2 (medium)	-3 (hard)		min. N	max. N	
				min.-max.kg	min.-max.kg	min.-max.kg				
mm	Nm/HB (max.)	Nm/h (max.)	min.-max.kg	min.-max.kg	min.-max.kg	V max. m/s	min. N	max. N	g	
USSK-M 0,5	7	25	67.500	5 - 22	20 - 180	150 - 480	3,5	11	18	65
USSK-M 1,0	8	40	68.000	8 - 36	33 - 280	250 - 750	3,5	15	20	105
USSK-M 1,1	12	70	105.000	10 - 80	50 - 490	460 - 1.500	3,5	17	30	200
USSK-M 1,25	12	90	135.000	15 - 120	85 - 690	600 - 1.870	3,5	17	30	270

Tlumičí charakteristika: samokompenzační lineární

Deceleration characteristic:

Rozsah teplot: - 20°C - +80°C

Temperature:

Integrovaný pevný doraz

Integrated End Stop

Těleso: ProSurf

Housing:

Pístnice: tvrdě chromovaná ocel

Piston rod: